

**SANTINT**

**AO200**



Net Efficiency | 200ml/minX5

Minimum Shot | 1/384Y(0.077ml)

Reliable simultaneous automatic dispenser, based on single piston pump, affordable price, and best total cost of ownership.



Item	Detail	Item	Detail
<b>Dispensing</b>	Piston Pump Simultaneous	<b>Minimum Shot</b>	1/384Y (0.077ml)
<b>Flow Rate</b>	500ml/min	<b>Canisters No.</b>	Up to 32
<b>Net Efficiency</b>	200ml/minX5	<b>Pump Capacity</b>	67ml
<b>Can Table</b>	Manual / Electric	<b>Canister Volume</b>	2.5/4.5L
<b>Tube Pressure Sensor</b>	Yes - Adjustable	<b>Dimension ( W x D x H )</b>	880x775x1185 ( 16 cans ) 1260x775x1185 (24 cans ) 1690x865x1305 (32 cans )
<b>Circulated Water Humidifying</b>	Yes	<b>Power Supply</b>	220V±10%/110V±10% , 50Hz/60Hz
<b>Automatic Nozzle Closure</b>	Yes	<b>Power</b>	250W
<b>Re-circulation System</b>	Yes	<b>Certificates</b>	CE/cTUVus

## Unique Inner Mainframe



- Innovative inner mainframe:  
16 pumps driven by 1 motor.
- Simple structure, easy maintenance.
- Minimum electric components.

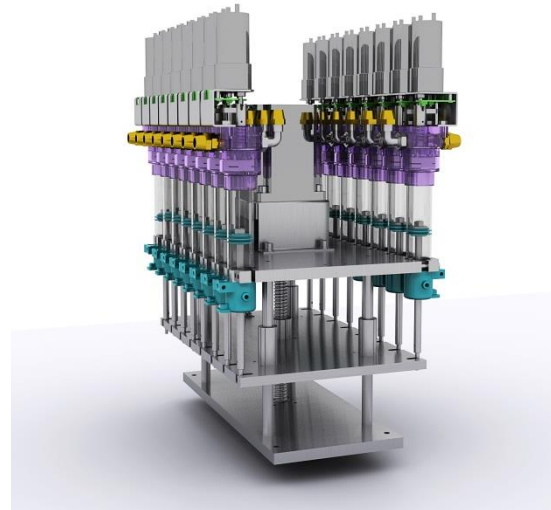

## Single Piston Pump X 5



- Classic single piston pump, the most reliable tech;
- Ceramic valve, reliable and durable;
- Re-calibration free;
- High Repeatability;
- Simultaneous X 5 Canisters



## Tube Pressure Sensor



- Alarm when nozzles blocked;
- No tube explosion, longer durability;
- Adjustable tube pressure sensor for various colorants.

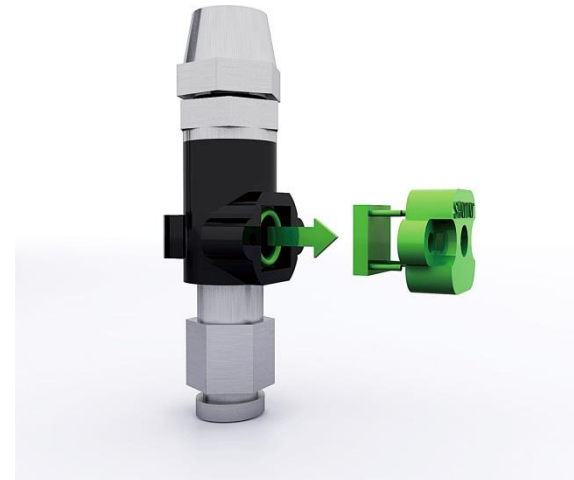

## Recirculation



- Recirculation from the valve;
- No sedimentation, drying or block in tubes, minimizing malfunction.

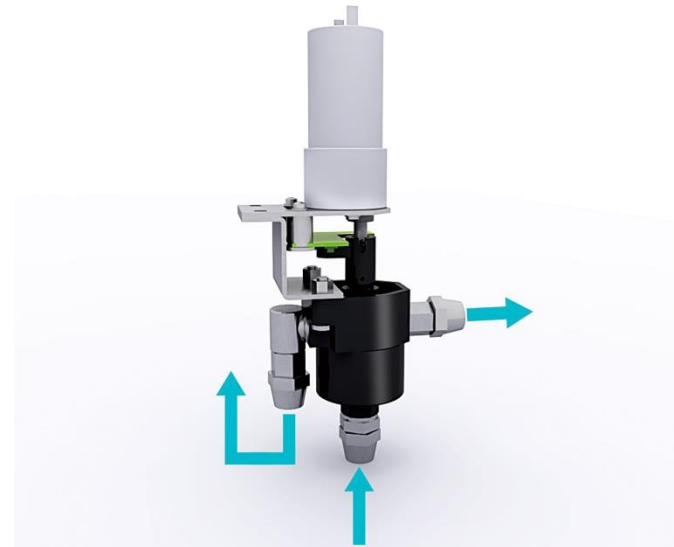

## Water Humidifier



- Unique water circulation system and humidifying device;
- Seal the nozzle and keep the moisture.
- Minimizing nozzle blockage.
- Rotary nozzle, easy to clean.

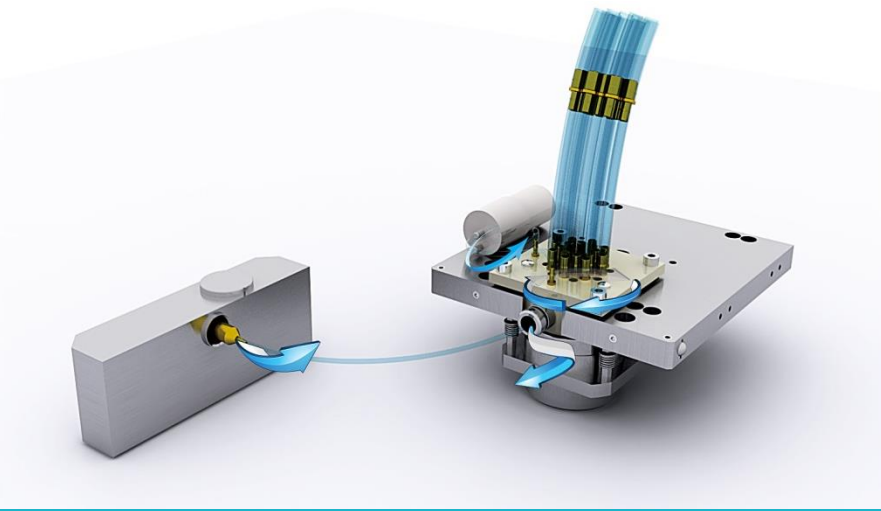

- 8 years' experience in dispensers;
- At least 5,500 sets in the market place;
- As a successor of A4 and AM200, AO has new design and proven quality.





## Robust & Reliable



- Sufficient testing and modifications before introducing to the market.

- More than 20 machines tested at customer factories and shops before formal purchasing.

- More than 40 companies are using Santint dispensers, e.g., Nippon, PPG, Sherwin, Valspar, etc



- Simple structure, compact design, affordable price, ideal machine to replace sequential dispenser.
- Improve dispensing efficiency for medium/small shop, small factory and warehouse; quicker delivery; better customer satisfaction.



- Simultaneous X 5 Canisters
- Piston Pump
- Calibration Free

**SANTINT**

**AO**

**SANTINT · CHINA**

Address: Xushui Industrial Trade  
Park, Zhengzhou.  
Tel: +86 371 6785 7168

**SANTINT · POLAND**

Address: ul. Postepu 19. mag.5  
02-676 Warszawa Polska  
Email: [info@santint.com](mailto:info@santint.com)

**SANTINT · U.S.A**

Address: 2000 Bloomingdale Road, Suite  
220, Glendale Heights, IL 60139  
Tel: +1 847 350 6911

**SANTINT · AUSTRALIA**

Address: 2/4 Weddel Court  
Laverton North Victoria  
Email: [info@santint.com](mailto:info@santint.com)